

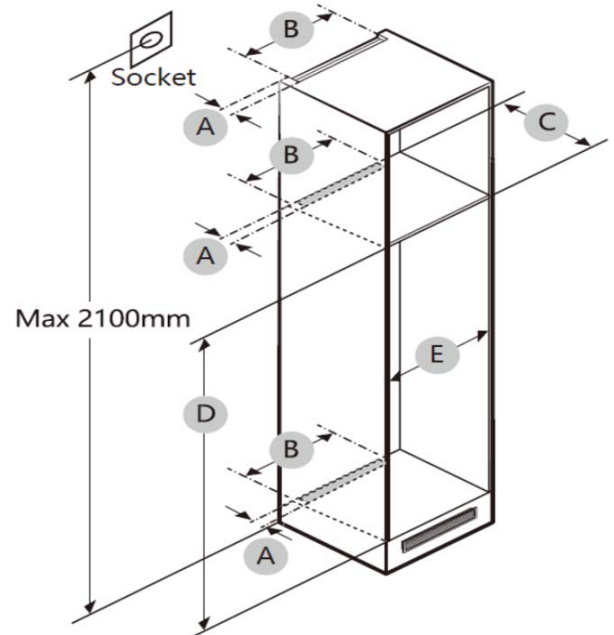

- Fully Integrated
- **E** Energy Efficiency
- Capacity: 315 liters
- 3 shelves
- 2 drawers
- Super Cooling function
- Automatic Defrost System
- Digital Display
- Height: 177,2 cm
- Width: 54cm
- Depth: 55cm
- Annual Energy Consumption (kWh) 115
- Noise level dB (A) 36



Model		A (mm)	B (mm)	C (mm)	D (mm)	E (mm)	Remark
CMT5518EVWF	Min.	50	400	560	1778	560	Hinge : 17mm
	Recommend			580	1780	562	
	Max.			-	1782	568	